

UNIVERSAL ACTIVE FILTER

FEATURES

- **LOW COST**
- **SMALL SIZE**
Single wide DIP package
- **FULLY CHARACTERIZED PARAMETERS**
- **HYBRID CONSTRUCTION**
- **IMPROVED PERFORMANCE**
1% frequency accuracy
Q range of 0.5 to 500
NPO capacitors and thin-film resistors
Uncommitted op amp included

BENEFITS

- **SAVES PRINTED CIRCUIT BOARD SPACE**
- **SAVES DESIGN TIME**
Calculate only four resistance values
Design directly from this data sheet
Versatile building block for filter design
- **HIGH RELIABILITY**
- **HIGH STABILITY**

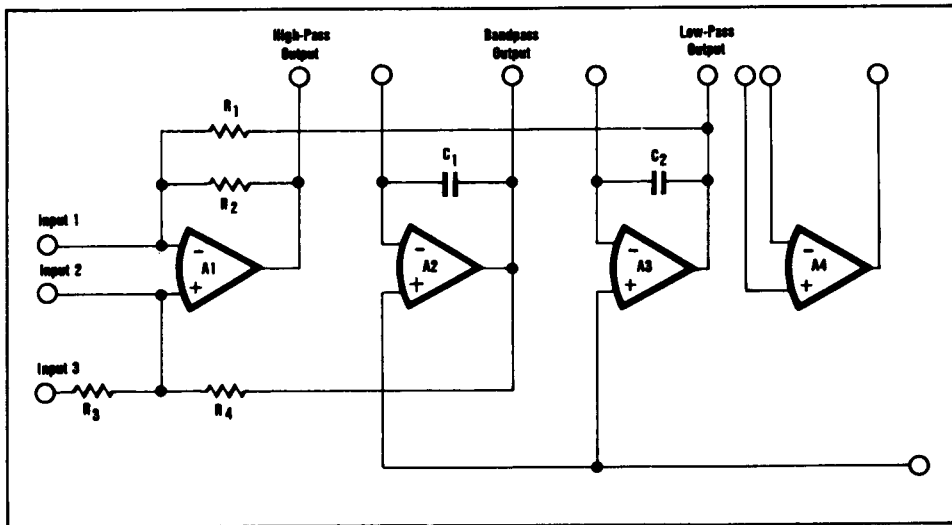

DESCRIPTION

The UAF41 is a versatile two-pole active filter. It uses a three operational amplifier double integrator feedback loop to generate a complex pole pair (two conjugate poles). The location of the poles in the complex plane (and thus the natural frequency and Q) are determined by external, user supplied resistors. Either three or four resistors are used depending on the particular configuration chosen.

The UAF41 produces three transfer functions simultaneously - low-pass, high-pass, and bandpass - which are available at three separate outputs. The fourth basic transfer function - the band-reject or notch - can be obtained simply by summing the high-pass and low-pass outputs using the uncommitted amplifier (A4) contained in the UAF41. The uncommitted op amp can also be used to add a single-pole response for complex filters requiring an odd number of poles.

More complex higher-order filters can readily be obtained by cascading UAF's. This is easily done with the UAF41 since the high input impedance and low output impedance associated with the operational amplifiers used prevents the series connected stages from interacting (e.g., no frequency pull due to following stage loading). This data sheet contains the design procedures for an easy selection of resistor values for the stagger tuning of cascaded stages.

The versatility of the UAF41 makes it a general purpose building block for a wide variety of active filter applications. Its universal nature, ease of use, small size, and low cost allows the user the convenience of keeping units on hand for immediate use whenever a filter requirement arises.

TRANSFER FUNCTION

The UAF41 uses the state variable technique to produce a basic second order transfer function. The equations describing the three outputs available are:

$$T(\text{Low-Pass}) = \frac{A_{LP}\omega_o^2}{s^2 + (\omega_o/Q)s + \omega_o^2}$$

$$T(\text{Bandpass}) = \frac{A_{BP}(\omega_o/Q)s}{s^2 + (\omega_o/Q)s + \omega_o^2}$$

$$T(\text{High-Pass}) = \frac{A_{HP}s^2}{s^2 + (\omega_o/Q)s + \omega_o^2}$$

To obtain band-reject characteristics the low-pass and

high-pass outputs are summed to form a pair of $j\omega$ axis zeros:

$$T(\text{Band-Reject}) = \frac{A(s^2 + \omega_o^2)}{s^2 + (\omega_o/Q)s + \omega_o^2}$$

where $A_{LP} = A_{HP} = A$.

The state variable approach uses two op amp integrators (A2 and A3 in the simplified schematic below) and a summing amplifier (A1) to provide simultaneous low-pass, bandpass, and high-pass responses. One UAF41 is required for each two poles of low-pass or high-pass filters and for each pole-pair of bandpass or band-reject filters.

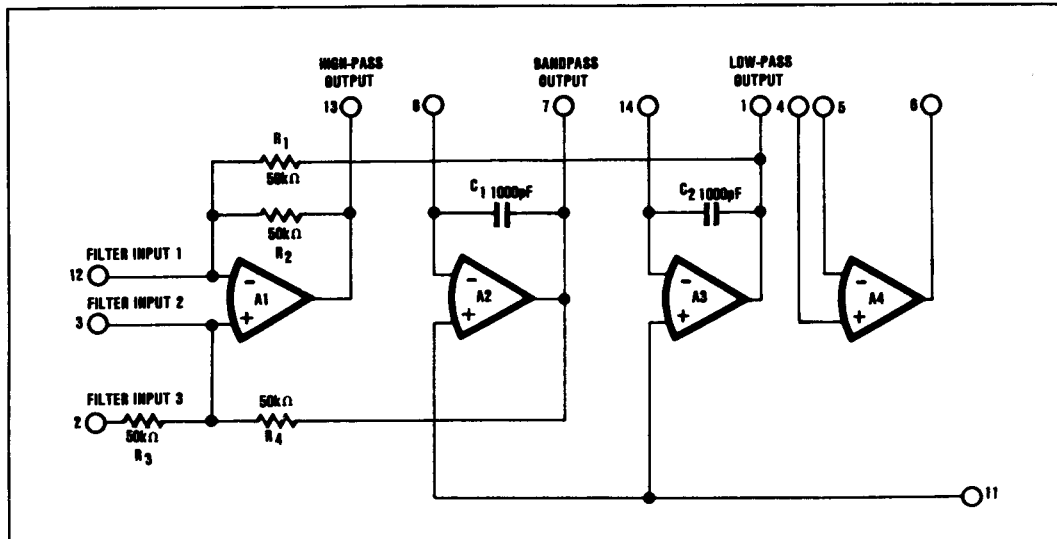

FIGURE 1. UAF41 Schematic.

SPECIFICATIONS

ELECTRICAL

Typical at 25°C and with rated supply unless otherwise noted.

MODEL	UAF41
INPUT	
Input Bias Current	±40nA
Input Voltage Range	±10V
Input Resistance ⁽¹⁾	50kΩ
TRANSFER CHARACTERISTICS	
Frequency Range (f _o)	0.001Hz to 25kHz
f _o Accuracy ⁽²⁾ , max	±1%
f _o Stability ⁽³⁾	±0.002%/°C
Q Range ⁽⁴⁾	0.5 to 500
Q Stability ⁽⁵⁾	
@ f _o Q ≤ 10 ⁴	±0.01%/°C
@ f _o Q ≤ 10 ⁵	±0.025%/°C
Q Repeatability at f _o Q ≤ 10 ⁵	±10%
Gain Range	0.1V/V to 50V/V
OUTPUT	
Peak-to-Peak Output Swing ⁽⁶⁾	20V
Output Offset ⁽⁷⁾	
(at L.P. output with unity gain)	±20mV
Output Impedance	1Ω
Noise ⁽⁸⁾	200μV, rms
Output Current ⁽⁹⁾	5mA
UNCOMMITTED AMP CHARACTERISTICS	
Input Offset Voltage	5mV
Input Bias Current	40nA
Input Impedance	1MΩ
Large Signal Voltage Gain	85dB
Output Current	5mA
POWER SUPPLIES	
Rated Power Supplies	±15VDC
Power Supply Range ⁽¹⁰⁾	±5VDC to ±18VDC
Supply Current @ ±15V (Quiescent), max	7mA
TEMPERATURE RANGE	
Specification Temperature Range	-25°C to +85°C
Storage Temperature Range	-25°C to +85°C

NOTES:

- For noninverting input configuration with App * 1.
- The tolerance of external frequency determining resistors must be added to this figure.
- T.C.R. of external frequency determining resistors must be added to this figure.
- See Performance Curves for Q_{max} vs F curve.
- Q stability varies with both the value of Q and the resonant frequency f_o.
- See Performance Curves for full power response curve.
- R_{F1} = R_{F2} < 100kΩ at low-pass output with unity gain.
- Measured at the bandpass output with Q @ 50 over DC to 50kHz.
- The current required to drive R_{F1} and R_{F2} (external) as well as C1 and C2 must come from this current.
- For supplies below ±10V, Q_{max} will decrease slightly; filters will operate below ±5V.

MECHANICAL

14-Pin Plastic DIP Package

NOTE:
Leads in true position within .010" (.25mm) R
⊙ MMC at seating plane.

DIM	INCHES		MILLIMETERS	
	MIN	MAX	MIN	MAX
A	.660	.785	16.76	19.94
B	.220	.280	5.59	7.11
C	—	.200	—	5.08
D	.015	.023	0.38	0.58
F	.030	.070	0.76	1.78
G	.100 BASIC		2.54 BASIC	
H	.030	.095		
J	.008	.015	0.20	0.38
K	.100	—	2.54	—
L	.300 BASIC		7.62 BASIC	
M	—	15°	—	15°
N	.020	.060	0.51	1.27

ROW SPACING: 7.63mm (0.300")
WEIGHT: 1.1 grams max

Pin material and plating composition conform to method 2003 (solderability) of MIL-STD-883 (except paragraph 3.2)

PIN CONNECTIONS

- Pin 1 - LOW-PASS OUTPUT
- Pin 2 - FILTER INPUT 3
- Pin 3 - FILTER INPUT 2
- Pin 4 - AUXILIARY AMP + INPUT
- Pin 5 - AUXILIARY AMP - INPUT
- Pin 6 - AUXILIARY AMP OUTPUT
- Pin 7 - BANDPASS OUTPUT
- Pin 8 - FREQUENCY ADJUST
- Pin 9 - NEGATIVE SUPPLY
- Pin 10 - POSITIVE SUPPLY
- Pin 11 - COMMON
- Pin 12 - FILTER INPUT 1
- Pin 13 - HIGH-PASS OUTPUT
- Pin 14 - FREQUENCY ADJUST

TYPICAL PERFORMANCE CURVES

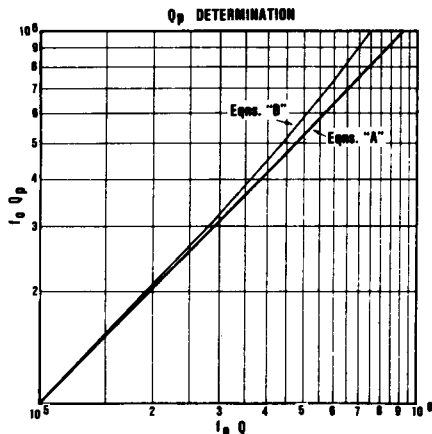
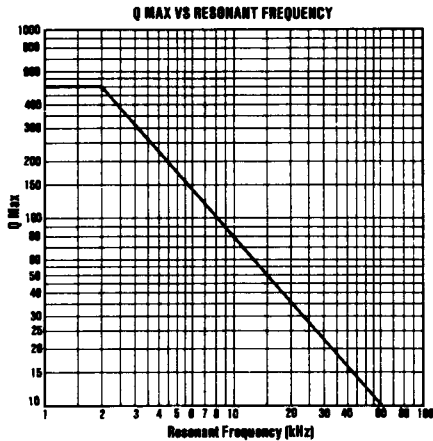
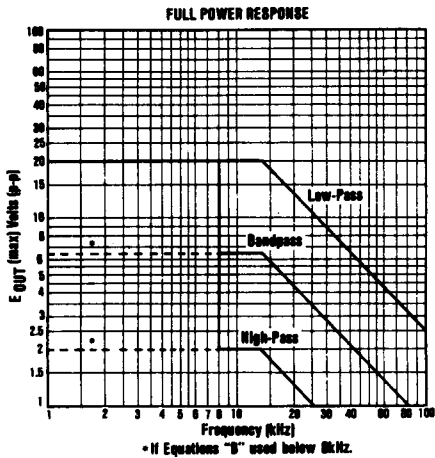

DESIGN PROCEDURE SUMMARY

This summary gives the design steps for the proper application of UAF41s and for the selection of the external components. More detailed information on filter theory pertinent to some of the steps can be found in the reference sources listed on last page.

DESIGN STEPS:

1. Choose the type of function (low-pass, bandpass, etc.), type of response (Butterworth, Bessel, etc.), number of poles, and cutoff frequency based on the particular application.
If the transfer function is band-reject see Band-Reject Transfer Function before proceeding to step 2.
2. Determine the normalized low-pass filter parameters (f_n and Q) based on the type of response and number of poles selected in step 1. See Normalized Low-Pass Parameters.
3. If the actual response desired is low-pass go to step 4. For other responses a transformation of variables must be made (low-pass to bandpass or low-pass to high-pass). See Low-Pass Transformation.
4. Determine the actual (denormalized) cutoff frequency, f_c , by multiplying f_n by the actual desired cutoff frequency. See Denormalization of Parameters.
5. Pick the desired UAF configuration (noninverting, inverting or bi-quad) see Configuration Selection Guide and UAF41 Configuration and Design Equations.
6. Decide whether to use design equations "A" or "B". See Design Equations "A" and "B".
7. Calculate R_{F1} and R_{F2} . See Natural Frequency and UAF Configurations and Design Equations.
8. Determine Q_p . See Q_p Procedure.
9. Select the desired gain for each UAF and calculate the corresponding R_G and R_Q . See Gain (A) and UAF41 Configurations and Design Equations.

NORMALIZED LOW-PASS PARAMETERS

Usual active filter design procedure involves using normalized low-pass parameters. Table I is provided to assist in this step for the more common filter responses. Table II is a BASIC program which allows f_n and Q to be calculated for any desired ripple and number of poles for the Chebyshev response. Consult the reference on last page for other information.

Note that for bandpass and high-pass filters, complex conjugate pole pairs in the actual filter correspond to single poles in the normalized low-pass model. Thus four poles in Table I would correspond to four-pole pairs (eight poles) in a bandpass or high-pass filter.

Filters with an odd number of poles show one f_n with no corresponding Q value. This represents a simple RC network that is required for odd pole filters. This RC network with a cutoff frequency equal to f_n times the overall filter cutoff frequency should be placed in series with the first UAF two-pole section. The uncommitted internal op amp with an external RC network can be used for this purpose.

The cutoff frequency determined by the Table I filter parameters is (1) the -3dB frequency of the Butterworth response and of the Bessel response and (2) the frequency at which the amplitude response of the Chebyshev filters passes through the maximum ripple band (to enter the stop band). A filter that is designed as a low-pass filter will not give the corresponding response as a band-pass filter.

TABLE I. Low-Pass Filter Parameters.

NUMBER OF POLES	BUTTERWORTH		CHEBYSCHEV					
			BESSEL		0.5dB RIPPLE		2dB RIPPLE	
	$f_n(1)$	Q	$f_n(1)$	Q	$f_n(2)$	Q	$f_n(2)$	Q
2	1.0	0.70711	1.2742	0.57735	1.23134	0.86372	0.907227	1.1286
3	1.0	-----	1.32475	-----	0.626456	-----	0.368911	-----
	1.0	1.0	1.44993	0.69104	1.068853	1.7062	0.941326	2.5516
4	1.0	0.54118	1.43241	0.52193	0.597002	0.70511	0.470711	0.9294
	1.0	1.3065	1.60594	0.80554	1.031270	2.9406	0.963678	4.59388
5	1.0	-----	1.50470	-----	0.362320	-----	0.218308	-----
	1.0	0.61805	1.55876	0.56354	0.690483	1.1778	0.627017	1.77509
	1.0	1.61812	1.75812	0.91652	1.017735	4.5450	0.97579	7.23228
6	1.0	0.51763	1.60653	0.51032	0.396229	0.68364	0.31611	0.9016
	1.0	0.70711	1.69186	0.61120	0.768121	1.8104	0.730027	2.84426
	1.0	1.93349	1.90782	1.0233	1.011446	6.5128	0.982828	10.4616
7	1.0	-----	1.68713	-----	0.256170	-----	0.155410	-----
	1.0	0.55497	1.71911	0.53235	0.503863	1.0916	0.460853	1.64642
	1.0	0.80192	1.82539	0.66083	0.822729	2.5755	0.797114	4.11507
	1.0	2.2472	2.05279	1.1263	1.008022	8.8418	0.987226	14.2802
8	1.0	0.50980	1.78143	0.50599	0.296736	0.67657	0.237699	0.89236
	1.0	0.60134	1.83514	0.55961	0.598874	1.6107	0.571925	2.5327
	1.0	0.89998	1.95645	0.71085	0.861007	3.4657	0.842486	5.58354
	1.0	2.5629	2.19237	1.2257	1.005984	11.5305	0.990142	18.6873

(1) -3 dB Frequency

(2) Frequency at which amplitude response passes through the ripple band.

NORMALIZED LOW-PASS CHEBYSCHEV

Table II gives a BASIC program for the determination of f_n and Q for a general normalized Chebyshev low-pass filter of any ripple and number of poles. Program inputs are the number of poles (N) and the peak-to-peak ripple (R). Program outputs are f_n and Q, which are used exactly as the values taken from Table I.

BAND-REJECT TRANSFER FUNCTION

The band-reject is achieved by summing the high-pass

and low-pass UAF outputs. Either of the configurations in Figures 3 and 4 can be used to provide the band-reject function if they are used as shown in Figure 2.

The 15kΩ resistor is adjusted for maximum rejection. The circuit in Figure 2 is applicable when using design equations "A" ($A_{LP} = A_{HP}$). When design equations "B" are used ($A_{LP} = 10A_{HP}$), the resistor at pin 1 must be 10 times the resistor at pin 13 to obtain equal pass-band gains above and below f_n .

In either case, the four external UAF resistors (R_G , R_Q , R_{F1} and R_{F2}) should be calculated for f_n and Q of the

band-reject filter desired and for A_{LP} to equal the desired pass-band gain. An input constraint is that the input voltage times A_{BP} must not exceed the rated peak-to-peak voltage of the bandpass output, or clipping will result. Note that the band-reject function is suitable only for a single UAF section. In a multi-section filter the inputs to successive stages are "preconditioned" by the preceding stages.

TABLE II. Low-Pass Chebyshev Program.

```

110 REM THIS IS A NORMALIZED LOW-PASS CHEBYSHEV PROGRAM
120 REM BY BARRY A. EHRLMAN
130 PRINT "NORMALIZED CHEBYSHEV"
140 PRINT "LOW-PASS FILTER"
150 PRINT
160 PRINT "BY BARRY A. EHRLMAN"
170 PRINT
180 PRINT
185 PI=3.1415927
190 PRINT "NUMBER OF POLES?"
200 INPUT N
210 PRINT
220 PRINT "PEAK-TO-PEAK RIPPLE IN DB?"
230 INPUT R
240 PRINT
250 A=SOR (EXP (R/4.3429448) -1)
260 B=1/A
270 AN=LOG (B+SOR (B^2+1))
280 RN=AN/N
290 L=INT (N/2)
300 J=INT ((N+1)/2)
310 FOR K=1 TO J
320 RP=( (EXP (AN) -EXP (-AN)) /2) +SIN (PI*((2*K)-1)/(2*N))
330 XIP=( (EXP (AN) +EXP (-AN)) /2) +COS (PI*((2*K)-1)/(2*N))
340 WN=SOR (RP^2+XIP^2)
350 Q=WN/(2*RP)
360 IF L<J AND K=J THEN 410
370 PRINT "FN=" ;WN
380 PRINT "Q=" ;Q
390 PRINT
400 GOTO 430
410 PRINT "FN=" ;WN
420 PRINT "Q=" ;RC POLE -
430 NEXT K
440 END

```

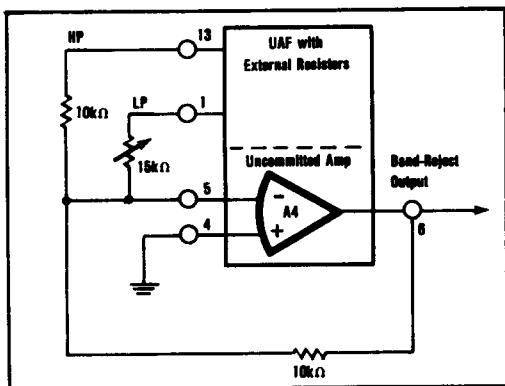

OFFSET ERROR ADJUSTMENT

DC offset errors will be minimized by grounding pin 3 through a resistor equal to 1/2 the value of R_{F1} or R_{F2} . The DC offset adjustment shown here may be used if required.

Offset errors will increase with increases in R_F .

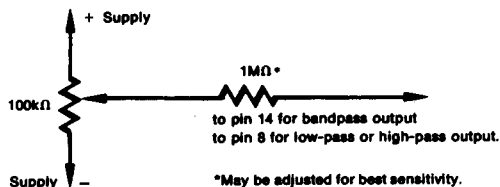

LOW-PASS TRANSFORMATION

LOW-PASS TO HIGH-PASS

The following simple transformation may be used for high-pass filters:

$$f_n \text{ (high-pass)} = \frac{1}{f_n \text{ (low-pass)}}$$

$$Q \text{ (high-pass)} = Q \text{ (low-pass)}$$

LOW-PASS TO BANDPASS

The low-pass to bandpass transformation to generate f_n (bandpass) and Q (bandpass) is much more complicated. It is tedious to do by hand but can be accomplished with the BASIC program given in Table III. This program automates the transformation

$$s = p/2 \pm \sqrt{(p/2)^2 - 1}$$

TABLE III. Low-Pass to Bandpass BASIC Transformation Program. (See last page of this PDS).

PROGRAM INPUTS:

1. f_n - From Table I for the low-pass filter of interest
2. Q - From Table I
3. Q_{BP} - Desired Q of the bandpass filter

For filters with an odd number of poles a Q of 0.5 should be used where Q is not given in Table I. Enter 10^5 for Q when transforming zeros on the imaginary axis.

The program transforms each low-pass pole into a bandpass pole pair. Thus a three-pole low-pass input, would result in the pole positions for a three-pole pair bandpass filter requiring three UAF stages.

DENORMALIZATION OF PARAMETERS

Table I shows filter parameters for many 2- to 8-pole normalized low-pass filters. The Q and the normalized undamped natural frequency, f_n for each two-pole section are shown. The Q values do not have to be denormalized and may be used directly as described in the Design Procedure Summary. f_n must be denormalized by multiplying it by the desired cutoff frequency of the actual overall filter to obtain the required frequency, f_o for the design formulas. As an example, consider a 4-pole low-pass Bessel filter with a cutoff frequency of 1000Hz. The first stage would be designed to an f_o of 1432.41Hz and a Q of 0.52193 while the second stage would have an f_o of 1605.94Hz and a Q of 0.80554. To combine the two stages into the composite filter the low-pass output of the first stage (pin 1) would be connected to the input resistors (R_G) of the second stage.

DESIGN EQUATIONS "A" AND "B"

1. For f_o below 8kHz, either of equations "A" or "B" may be used.
2. For f_o above 8kHz, equations "B" must be used. If equations "A" were used above 8kHz, the filter could become unstable.
3. Equations "A" are for the UAF as it is supplied. When using equations "B", a 5.49k Ω resistor must be placed in parallel with R_2 (between pins 12 and 13).
4. The values of R_{F1} and R_{F2} calculated with equations "B" are approximately one-third of those calculated with equations "A". Thus there may be an advantage in using equation "B" at low frequencies. Using equation "B" would require use of one more resistor, but that would not alter or affect filter performance in any manner.
5. Using the negative gain values for A_{LP} or A_{HP} or A_{BP} could result in the negative values for resistors R_G and R_Q . So the absolute value of the gain should always be used in the equations.

GAIN (A)

1. The gain (V/V) of each filter section is:
 A_{LP} - for low-pass output - gain at DC
 A_{BP} - for bandpass output - gain at f_o
 A_{HP} - for high-pass output - gain at high frequencies.
2. Refer to Performance Curves for full power response.

When selecting the gain, insure that the limits of the curve are not exceeded for the desired voltage range.

NATURAL FREQUENCY (f_o)

1. f_o for each one pole-pair bandpass filter is the center frequency (f_c). f_c is defined as $f_c = \sqrt{f_1 f_2}$ where f_1 is the lower -3dB point and f_2 is the upper -3dB point of the pole pair response.
2. To obtain f_o below 100Hz using practical resistor values, capacitors may be paralleled with C1 and C2 to reduce the size of R_{F1} and R_{F2} . If capacitors are added in parallel,

$$R_{F1}(\text{new}) = R_{F2}(\text{new}) = R_{F1}(\text{old}) \frac{1000\text{pF}}{C + 1000\text{pF}}$$

where R_F (new) is the new lower value frequency resistor, C is the value of the two external capacitors placed across C1 and C2 (between pins 7 and 8 and pins 1 and 14 and R_{F1} (old) is the value calculated in the simplified design equations.

Q-FACTOR

1. For bandpass filters $Q = \frac{f_o}{3\text{dB bandwidth}}$
2. When designing low-pass filters of more than two poles, best results will be obtained if the two pole sections with lower Q are followed by the sections with higher Q. This will eliminate any possibility of clipping due to high gain ripple in high Q sections.
3. Q repeatability (Q change from unit-to-unit) is typically $\pm 5\%$ for $f_o Q$ products less than 10^4 . The Q repeatability error increases as the $f_o Q$ product increases to approximately $\pm 10\%$ for $f_o Q$ products near 10^5 .

Q_F PROCEDURE

1. If the " f_o times Q" product is greater than 10^5 , it is possible for the measured filter Q to be different from the calculated value of Q. This effect is the result of non-ideal characteristics of operational amplifiers. It can be compensated for by introducing the parameter Q_F into the design equations.
2. Calculate the $f_o Q$ product for the filter. If the product is above 10^5 Hz, locate the corresponding $f_o Q_F$ product in the Performance Curves. Divide $f_o Q_F$ by f_o to obtain Q_F . Use Q_F as indicated in the design equations. For $f_o Q$ products below 10^5 Hz, $Q_F = Q$.

CONFIGURATION SELECTION GUIDE

It is possible to configure the UAF41 three different ways. Each configuration produces features that may or may not be desirable for a specific application. This selection guide is given to assist in determining the most advantageous configuration for a particular application.

	NONINVERTING INPUT	INVERTING INPUT	BI QUAD
Outputs Available	BP, LP and HP	BP, LP and HP	BP and LP
Outputs Inverted with respect to the Input	BP	HP and LP	BP and LP
Q & Gain Independent of Frequency Resistors?	Yes	Yes	No
Type of Q Variation With Changes in R_F	Constant Q	Constant Q	Constant Bandwidth
Other Advantages	May eliminate one external resistor (use internal R_3 as R_G)		R_G and R_Q are small at high frequencies. Easy single-supply operation.
Parameter Limitations	$2 Q_p - A_{BP} > 1$ (Eqns. "A") $3.48 Q_p - A_{BP} > 1$ (Eqns. "B")	$2 Q_p + A_{BP} > 1$ (Eqns. "A") $3.48 Q_p + A_{BP} > 1$ (Eqns. "B")	No HP Output
<p>Summary: The Bi-Quad filter is particularly useful as a bandpass filter if the filter bandwidth must be kept constant as the center frequency is varied. If Q must be kept constant (i.e., constant Q of a bandpass or maintaining a constant response of a low-pass or high-pass) one of the other two configurations should be used. The Bi-Quad also has the advantage that R_G and R_Q are smaller than with the other two configurations (this is especially useful at high frequencies). The noninverting input configuration has the advantage that for $A_{BP} = 1$, $R_G = 50k\Omega$; therefore R_3 (internal) may be used so that only three external resistors are needed (R_{F1}, R_{F2}, R_Q). For single supply operation of the UAF41 in bi-quad filters, bias pin 3 and pin 11 to $1/2 + V_{CC}$.</p>			

UAF41

5

ANALOG CIRCUIT FUNCTIONS

UAF41 CONFIGURATIONS AND DESIGN EQUATIONS

NONINVERTING INPUT CONFIGURATION

SIMPLIFIED DESIGN EQUATIONS "A"

$$1. R_{F1} = R_{F2} = \frac{10^9}{\omega_o} = \frac{1.592 \times 10^8}{f_o}$$

$$2. A_{BP} = Q A_{LP} = Q A_{HP}$$

$$3. R_G = \frac{5.0 \times 10^4 Q}{A_{BP} Q_p}$$

$$4. R_Q = \frac{5.0 \times 10^4}{2Q_p - A_{BP} Q_p - 1}$$

SIMPLIFIED DESIGN EQUATIONS "B"

Must be used for $f_o > 8KHz$

$$1. R_{F1} = R_{F2} = \frac{\sqrt{10} \times 10^8}{\omega_o} = \frac{5.033 \times 10^7}{f_o}$$

$$2. A_{BP} = \frac{Q}{3.16} A_{LP} = 3.16 Q A_{HP}$$

$$3. R_G = \frac{5.0 \times 10^4 Q}{A_{BP} Q_p}$$

$$4. R_Q = \frac{5.0 \times 10^4}{3.48 Q_p - A_{BP} Q_p - 1}$$

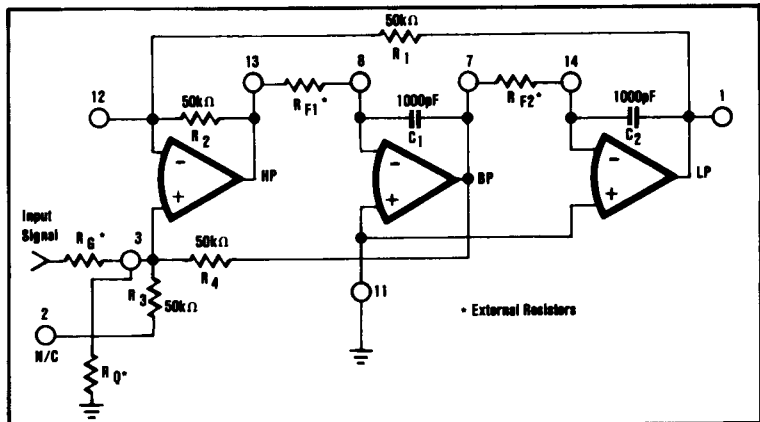

FIGURE 3. Noninverting Input Configuration.

SIMPLIFIED DESIGN EQUATIONS "A"

- $R_{F1} = R_{F2} = \frac{10^9 \cdot 1.592 \times 10^8}{f_0}$
- $A_{BP} = Q_p A_{LP} = Q_p A_{HP}$
- $R_G = \frac{5.0 \times 10^4 Q_p}{A_{BP}}$
- $R_Q = \frac{5.0 \times 10^4}{2Q_p + A_{BP} - 1}$

SIMPLIFIED DESIGN EQUATIONS "B"

Must be used for $f_0 \geq 8\text{kHz}$

- $R_{F1} = R_{F2} = \frac{\sqrt{10} \times 10^8}{\omega_0} = \frac{5.033 \times 10^7}{f_0}$
- $A_{BP} = \frac{Q_p}{3.16} A_{LP} = 3.16 Q_p A_{HP}$
- $R_G = \frac{1.58 \times 10^4 Q_p}{A_{BP}}$
- $R_Q = \frac{5.0 \times 10^4}{3.48 Q_p + A_{BP} - 1}$

SIMPLIFIED DESIGN EQUATIONS "A"

- $R_{F1} = R_{F2} = \omega_0^{-1} \frac{10^9 \cdot 1.592 \times 10^8}{f_0}$
- $A_{BP} = Q A_{LP}$
- $R_Q = Q_p R_{F1}$
- $R_G = \frac{R_Q}{A_{BP}}$

SIMPLIFIED DESIGN EQUATIONS "B"

Must be used for $f_0 \geq 8\text{kHz}$

- $R_{F1} = R_{F2} = \frac{\sqrt{10} \times 10^8}{\omega_0} = \frac{5.033 \times 10^7}{f_0}$
- $A_{BP} = 3.16 Q A_{LP}$
- $R_Q = 3.16 Q_p R_{F1}$
- $R_G = \frac{R_Q}{A_{BP}}$

† To use equations "B" connect a 5.49kΩ resistor between pins 12 and 13.
Equations "B" are also valid for frequencies below 8kHz.

INVERTING INPUT CONFIGURATION

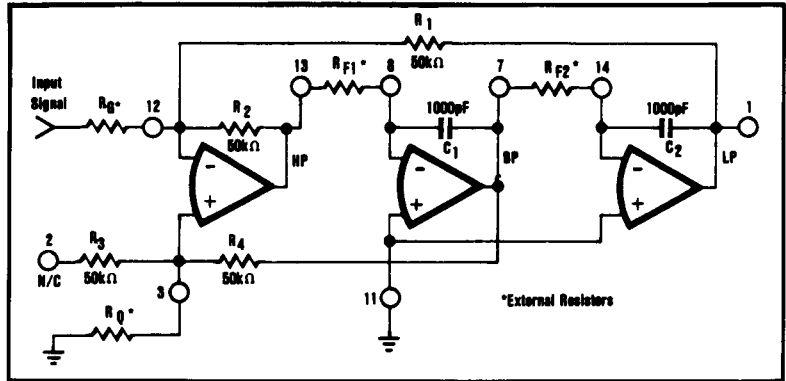

FIGURE 4. Inverting Input Configuration.

BI-QUAD CONFIGURATION

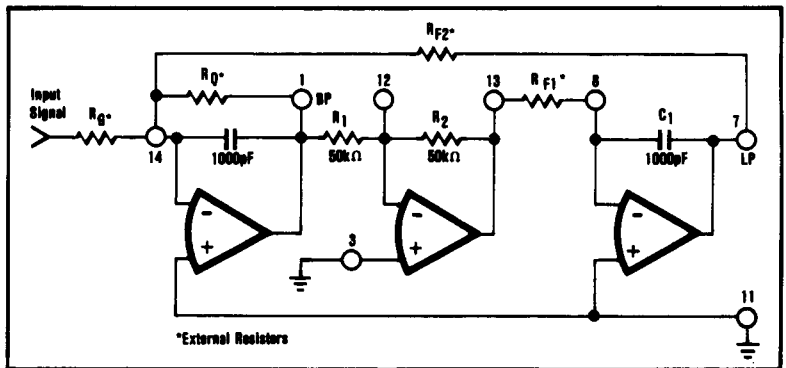

FIGURE 5. Bi-Quad Configuration.

DETAILED TRANSFER FUNCTION EQUATIONS

The following equations show the action of all the internal and external UAF41 filter components. They are not required for the regular design procedure but could be used if a detailed analysis is required.

NONINVERTING INPUT CONFIGURATION

- $\omega_0^2 = \frac{R_2}{R_1 R_{F1} R_{F2} C_1 C_2}$
- $Q = \frac{1 + \frac{R_4(R_G + R_Q)}{R_G R_Q}}{1 + \frac{R_2}{R_1}} \left(\frac{R_2 R_{F1} C_1}{R_1 R_{F2} C_2} \right)^{1/2}$
- $Q A_{LP} = Q A_{HP} \left(\frac{R_1}{R_2} \right) = A_{BP} \left(\frac{R_1 R_{F1} C_1}{R_2 R_{F2} C_2} \right)^{1/2}$
- $A_{LP} = \frac{1 + \frac{R_1}{R_2}}{R_G \left(\frac{1}{R_G} + \frac{1}{R_Q} + \frac{1}{R_4} \right)}$
- $A_{HP} = \frac{R_2}{R_1} A_{LP} = \frac{1 + \frac{R_2}{R_1}}{R_G \left(\frac{1}{R_G} + \frac{1}{R_Q} + \frac{1}{R_4} \right)}$
- $A_{BP} = \frac{R_4}{R_G}$

INVERTING INPUT CONFIGURATION

- $\omega_0^2 = \frac{R_2}{R_1 R_{F1} R_{F2} C_1 C_2}$
- $Q = \left(1 + \frac{R_4}{R_Q} \right) \left(\frac{1}{\frac{1}{R_1} + \frac{1}{R_2} + \frac{1}{R_G}} \right) \left(\frac{R_{F1} C_1}{R_1 R_2 R_{F2} C_2} \right)^{1/2}$
- $Q A_{LP} = Q A_{HP} \left(\frac{R_1}{R_2} \right) = A_{BP} \left(\frac{R_1 R_{F1} C_1}{R_2 R_{F2} C_2} \right)^{1/2}$
- $A_{LP} = \frac{R_1}{R_G}$
- $A_{HP} = \frac{R_2}{R_1} A_{LP} = \frac{R_2}{R_G}$
- $A_{BP} = \left(1 + \frac{R_4}{R_Q} \right) \frac{1}{R_G \left(\frac{1}{R_1} + \frac{1}{R_2} + \frac{1}{R_G} \right)}$

BI-QUAD CONFIGURATION

- $\omega_0^2 = \frac{R_2}{R_1 R_{F1} R_{F2} C_1 C_2}$
- $Q = R_Q C_2 \omega_0$
- $A_{BP} = \frac{Q A_{LP}}{\omega_0 R_{F2} C_2} = \frac{R_Q}{R_{F2} C_2}$

ACTIVE FILTER DESIGN EXAMPLES USING THE DESIGN PROCEDURE OUTLINED IN DESIGN STEPS SECTION.

Example 1.

It is desired to design a three-pole, 0.5dB ripple, Chebyshev High-Pass Filter; the cutoff frequency $f_c = 2\text{kHz}$, Gain $A_{HP} = +1$.

Step 1.

The type of transfer function (high-pass), the type of response (Chebyshev), number of poles (3), and the cut off frequency (f_c) are chosen depending upon the particular application and are stated in the example.

Step 2.

Normalized low-pass filter parameters f_n and Q are obtained from Table I (or from program shown in Table II).

Complex Poles:

$$\left. \begin{aligned} f_n &= 1.068853 \\ Q &= 1.7062 \end{aligned} \right\}$$

Simple Pole:

$$f_n = 0.626456$$

Step 3.

Now, since the actual response desired is high-pass, the low-pass to high-pass transformation must be made as previously discussed in Low-Pass Transformation.

$$f_n (\text{high-pass}) = \frac{1}{f_n (\text{low-pass})}, \quad Q_{HP} = Q_{LP}$$

∴ For Complex Poles:

$$f_n = \frac{1}{1.068853} = 0.935582$$

and $Q = 1.7062$

$$\text{For Simple Pole: } f_n = \frac{1}{0.626456} = 1.596281$$

Step 4.

Now, determine the actual (denormalized) frequency.
 $f_o = f_c \times f_n = 2\text{kHz} \times 0.935582 = 1871.2\text{Hz}$

Step 5.

Refer to the Configuration Selection Guide. Since the gain required is positive, the HP output is not inverted with respect to the input. Therefore, the noninverting input configuration must be selected. Note that the HP output is not available with the Bi-Quad configuration.

Step 6.

Since $f_o < 8\text{kHz}$, Equations "A" would be used.

Step 7.

For the Complex Poles Stage of the filter, using the equations "A".

$$R_{F1} = R_{F2} = \frac{1.592 \times 10^3}{1871.2} = 85.08\text{k}\Omega$$

Step 8.

$$f_o Q = 1871.2 \times 1.7062 = 3.19 \times 10^3$$

$$\therefore f_o Q < 10^5$$

$$\therefore Q_P = Q = 1.7062$$

Step 9.

$$A_{BP} = Q_P \times A_{HP} = 1.7062 \times 1 = 1.7062$$

$$R_G = \frac{5.0 \times 10^4 \times 1.7062}{1.7062 \times 1.7062} = 29.3\text{k}\Omega$$

$$R_Q = \frac{5.0 \times 10^4}{2 \times 1.7062 - 1.7062 - 1} = 70.8\text{k}\Omega$$

The above obtained resistor values are for the complex pole pair of the first stage of the required active filter. The simple pole obtained as outlined below, using the uncommitted op amp in the UAF41 makes the second stage of the required filter.

For the simple pole f_n was obtained in step 3.

$$f_n = 1.596281$$

$$\text{The actual (denormalized) frequency} = f_c \times f_n \\ = 2\text{kHz} \times 1.596281 = 3192.6\text{Hz}$$

$$\text{Now, } f = \frac{1}{2\pi RC}$$

$$\therefore RC = \frac{1}{2\pi f} = \frac{1}{2\pi \times 3192.6} = 4.9851 \times 10^{-5}$$

Choosing $C = 2200\text{pF}$ (or any convenient value),

$$R = \frac{4.9851 \times 10^{-5}}{2200 \times 10^{-12}} = 22.66\text{k}\Omega$$

Note:

R and/or C may be chosen in any convenient manner to obtain the desired RC product.

The overall circuit for the required filter is shown below:

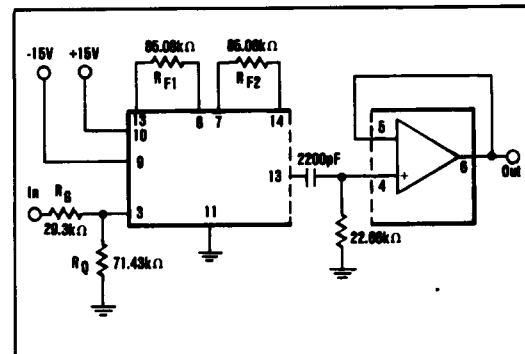

FIGURE 6. Overall Circuit - Example 1.

Example 2.

It is desired to design a 4-pole Butterworth, Bandpass Filter, with $Q = 25$, $f_c = 19\text{kHz}$ and $A_{BP} = 1$.

Using the computer program shown in Table III, the following values of f_n and Q are obtained.

$$f_n = 1.0142435, Q = 35.36541$$

and

$$f_n = 0.9859565, Q = 35.35886$$

Using the above shown values of Q and f_n , we now will proceed to design the two stages of filter separately. Composite gain will be ≤ 1 . Any one of the three configurations shown in the Configuration Selection Guide can be used. We will select the noninverting input configuration.

For Stage 1.

$$f_o = 19\text{kHz} \times f_n = 19\text{kHz} \times 1.0142435 = 19270.6\text{Hz}$$

Since $f_o > 8\text{kHz}$, equations "B" would be used.

$$R_{F1} = R_{F2} = \frac{5.033 \times 10^7}{19270.6} = 2.6118\text{k}\Omega$$

$$f_o Q = 19270.6 \times 35.36541 = 6.815136 \times 10^5$$

Since $f_o Q > 10^5$, locate the corresponding $f_o Q_P$ from the Performance Curves.

Divide $f_o Q_P$ by f_o to obtain Q_P .

$$\text{Thus } Q_P = 48.78$$

$$R_G = \frac{5.0 \times 10^4 \times 35.36541}{1 \times 48.78} = 36.25\text{k}\Omega$$

$$R_Q = \frac{5.0 \times 10^4}{3.48 \times 47.78 - \frac{48.78}{35.37} - 1} = 298.7\Omega$$

For Stage 2.

Following the same procedure as shown for Stage 1 above, the values shown below are obtained.

$$f_o Q = 6.624 \times 10^5, \text{ using the Performance Curves,}$$

$$Q_P = 48.04$$

$$R_{F1} = R_{F2} = 2.6867\text{k}\Omega$$

$$R_G = 36.8\text{k}\Omega$$

$$\text{and } R_Q = 303.4\Omega$$

The overall circuit for the required filter is shown below.

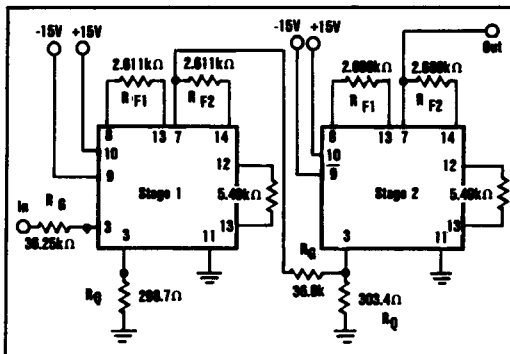

FIGURE 7. Overall Circuit - Example 2.

Example 3.

It is desired to design a 5-pole Bessel, Low-Pass Filter with $f_c = 3.3\text{kHz}$ and $A_{LP} = 1$.

From Table I the following values of f_n and Q are obtained.

Complex Poles:

$$f_n = 1.55876$$

$$Q = 0.56354$$

$$f_n = 1.75812$$

$$Q = 0.91652$$

Simple Pole:

$$f_n = 1.50470$$

Using the above shown values of f_n and Q , we now will proceed to design the three stages of filter separately.

Any one of the three configurations can be used. We will select inverting configuration.

For Stage 1.

$$f_o = 3.3\text{kHz} \times f_n = 3.3\text{kHz} \times 1.55876 = 5144\text{Hz}$$

Since $f_o < 8\text{kHz}$, equations "A" would be used.

$$R_{F1} = R_{F2} = \frac{1.592 \times 10^4}{5144} = 30.95\text{k}\Omega$$

$$f_o Q = 5144 \times 0.56354 = 2.9 \times 10^3$$

$$f_o Q < 10^5, \therefore Q_P = Q = 0.56354$$

$$A_{BP} = Q_P A_{LP} = 0.56354 \times 1 = 0.56354$$

$$R_G = \frac{5 \times 10^4 \times 0.56354}{0.56354} = 50\text{k}\Omega$$

$$R_Q = \frac{5 \times 10^4}{2 \times 0.56354 + 0.56354 - 1} = 72.4\text{k}\Omega$$

For Stage 2.

$$f_o = 3.3\text{kHz} \times f_n = 3.3\text{kHz} \times 1.75812 = 5802\text{Hz}$$

Since $f_o > 8\text{kHz}$, equations "A" would be used.

$$R_{F1} = R_{F2} = \frac{1.592 \times 10^4}{5802} = 27.44\text{k}\Omega$$

$$f_o Q = 5802 \times 0.91652 = 5.32 \times 10^3$$

$$f_o Q > 10^5, \therefore Q_P = Q = 0.91652$$

$$A_{BP} = Q_P A_{LP} = 0.91652 \times 1 = 0.91652$$

$$R_G = \frac{5 \times 10^4 \times 0.91652}{0.91652} = 50\text{k}\Omega$$

$$R_Q = \frac{5 \times 10^4}{2 \times 0.91652 + 0.91652 - 1} = 28.58\text{k}\Omega$$

For Stage 3.

$$f = 3.3\text{kHz} \times f_n = 3.3\text{kHz} \times 1.50470 = 4966\text{Hz}$$

For the simple pole,

$$RC = \frac{1}{2\pi f} = \frac{1}{2\pi \times 4966} = 3.2049 \times 10^{-5}$$

3300pF (or any convenient value)

$$R = \frac{3.2049 \times 10^{-5}}{3300 \times 10^{-12}} = 9.71 \text{ k}\Omega$$

The overall circuit is shown below.

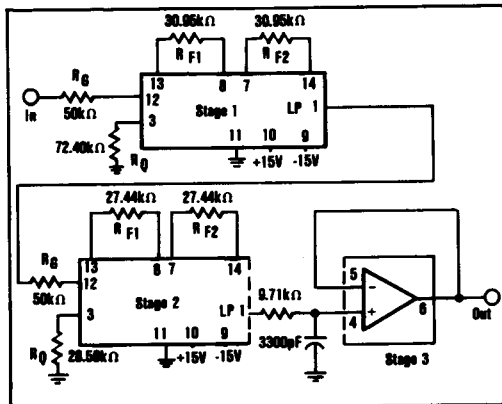

FIGURE 8. Overall Circuit - Example 3.

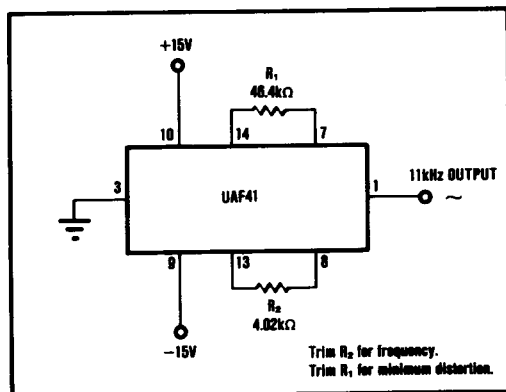

FIGURE 9. Using the UAF41 as an Oscillator.

USEFUL REFERENCES

1. G.E. Tobey, J.G. Graeme and L.P. Huelsman, *Operational Amplifiers: Design and Applications*, (Chapter 8) McGraw Hill Book Co., 1971.
2. Yu Jen Wong, William E. Ott, *Function Circuits: Design and Applications*, (Chapter 6) McGraw Hill Book Co., 1976.
3. Richard W. Daniels, *Approximation Methods for Electronic Filter Design*, McGraw Hill Book Co., 1974.
4. Anatol I. Zverev, *Handbook of Filter Synthesis*, John Wiley and Sons Inc., New York, N.Y., 1967
5. Gabor C. Temes, Sanjit K. Mitra, *Modern Filter Theory and Design*, John Wiley and Sons, New York, N.Y., 1973

TABLE III. Low-Pass to Bandpass BASIC Transformation Program.

```

20 INPUT "FN, Q, AND Q(BANDPASS)";F,Q,QBP
30 Y=F*SQR(1-(1/(2*Q))^2)
40 X=-F/(2*Q)
50 PX=X:PY=Y
60 FOR I= 1 TO 2
70 SX=PX/(2*QBP):SY=PY/(2*QBP)
80 PX=(SX^2-SY^2)-1:PY=2*SX*SY
90 T=ATN(PY/PX)
95 T=T-3.1415926#
100 IF T > 0 THEN 120
110 T = 2*3.1415926# + T
120 T=T/2
130 A=SQR(SQR(PX^2 + PY^2))*COS(T)
140 B=SQR(SQR(PX^2 + PY^2))*SIN(T)
150 SX=SX+A:SY=SY+B
160 F=SQR(SX^2 +SY^2)
170 Q=- F/(2*SX)
180 PRINT "FN=";F;"Q=";Q
190 IF Y=0 THEN 220
200 PX=X:PY=- Y
210 NEXT I
220 STOP
230 END

```