

# Precision IC Comparator Runs from +5V Logic Supply

National Semiconductor  
Application Note 41  
Robert J. Widlar  
October 1970



Precision IC Comparator Runs from +5V Logic Supply

## Introduction

In digital systems, it is sometimes necessary to convert low level analog signals into digital information. An example of this might be a detector for the illumination level of a photo-diode. Another would be a zero crossing detector for a magnetic transducer such as a magnetometer or a shaft-position pickoff. These transducers have low-level outputs, with currents in the low microamperes or voltages in the low millivolts. Therefore, low level circuitry is required to condition these signals before they can drive logic circuits.

A voltage comparator can perform many of these precision functions. A comparator is essentially a high-gain op amp designed for open loop operation. The function of a comparator is to produce a logic "one" on the output with a positive signal between its two inputs or a logic "zero" with a negative signal between the inputs. Threshold detection is accomplished by putting a reference voltage on one input

and the signal on the other. Clearly, an op amp can be used as a comparator, except that its response time is in the tens of microseconds which is often too slow for many applications.

A unique comparator design will be described here along with some of its applications in digital systems. Unlike older IC comparators or op amps, it will operate from the same 5V supply as DTL or TTL logic circuits. It will also operate with the single negative supply used with MOS logic. Hence, low level functions can be performed without the extra supply voltages previously required.

The versatility of the comparator along with the minimal circuit loading and considerable precision recommend it for many uses, in digital systems, other than the detection of low level signals. It can be used as an oscillator or multivibrator, in digital interface circuitry and even for low voltage analog circuitry. Some of these applications will also be discussed.

## Circuit Description

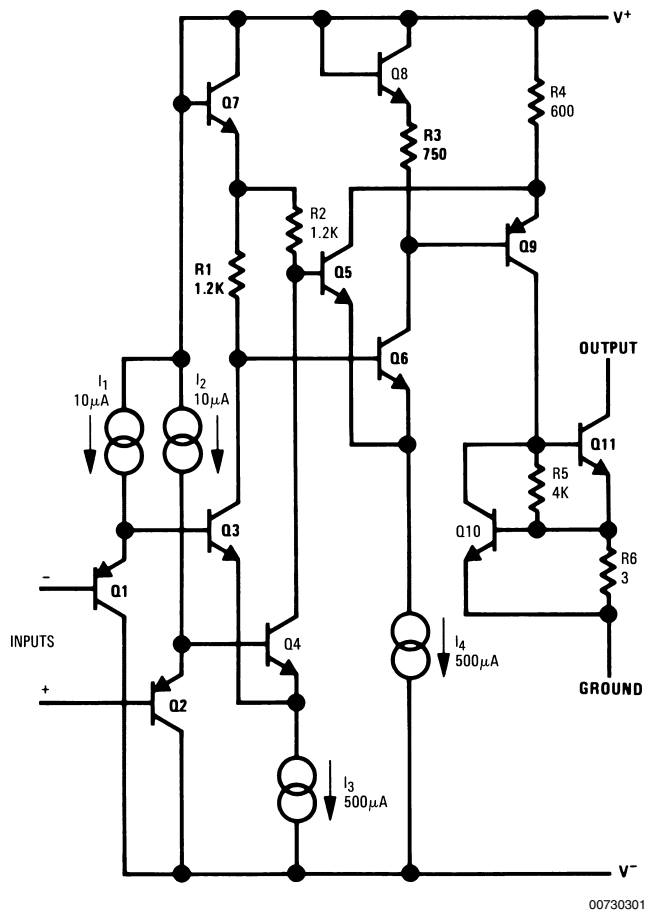

FIGURE 1. Simplified Schematic of the Comparator

AN-41

## Circuit Description (Continued)

In order to understand how to use this comparator, it is necessary to look briefly at the circuit configuration. *Figure 1* shows a simplified schematic of the device. PNP transistors buffer the differential input stage to get low input currents without sacrificing speed. The PNP's drive a standard NPN differential stage,  $Q_3$  and  $Q_4$ . The output of this stage is further amplified by the  $Q_5$ — $Q_6$  pair. This feeds  $Q_9$  which provides additional gain and drives the output stage. Current sources are used to determine the bias currents, so that performance is not greatly affected by supply voltages.

The output transistor is  $Q_{11}$ , and it is protected by  $Q_{10}$  and  $R_6$  which limit the peak output current. The output lead, since it is not connected to any other point in the circuit, can either be returned to the positive supply through a pull-up resistor or switch loads that are connected to a voltage higher than the positive supply voltage. The circuit will operate from a single supply if the negative supply lead is connected to ground. However, if a negative supply is available, it can be used to increase the input common mode range.

*Table 1* summarizes the performance of the comparator when operating from a 5V supply. The circuit will work with supply voltages up to  $\pm 15V$  with a corresponding increase in the input voltage range. Other characteristics are essentially unchanged at the higher voltages.

**TABLE 1. Important electrical characteristics of the LM111 comparator when operating from single, 5V supply ( $T_A = 25^\circ C$ )**

Parameter	Limits			Units
	Min	Typ	Max	
Input Offset Voltage		0.7	3	mV
Input Offset Current		4	10	nA
Input Bias Current		60	100	nA
Voltage Gain		100		V/mV
Response Time		200		ns
Common Mode Range	0.3		3.8	V
Output Voltage Swing			50	V
Output Current			50	mA
Fan Out (DTL/TTL)	8			
Supply Current		3	5	mA

## Low Level Applications

A circuit that will detect zero crossing in the output of a magnetic transducer within a fraction of a millivolt is shown in *Figure 2*. The magnetic pickup is connected between the two inputs of the comparator. The resistive divider,  $R_1$  and  $R_2$ , biases the inputs 0.5V above ground, within the common mode range of the IC. The output will directly drive DTL or TTL. The exact value of the pull up resistor,  $R_5$ , is determined by the speed required from the circuit since it must drive any capacitive loading for positive-going output signals. An optional offset-balancing circuit using  $R_3$  and  $R_4$  is included in the schematic.

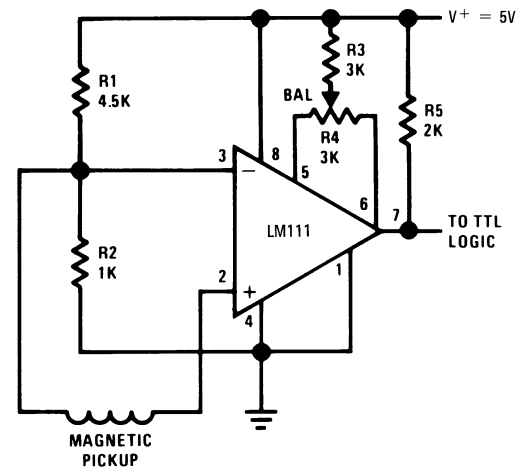

00730302

**FIGURE 2. Zero Crossing Detector for Magnetic Transducer**

*Figure 3* shows a connection for operating with MOS logic. This is a level detector for a photodiode that operates off a  $-10V$  supply. The output changes state when the diode current reaches  $1 \mu A$ . Even at this low current, the error contributed by the comparator is less than 1%.

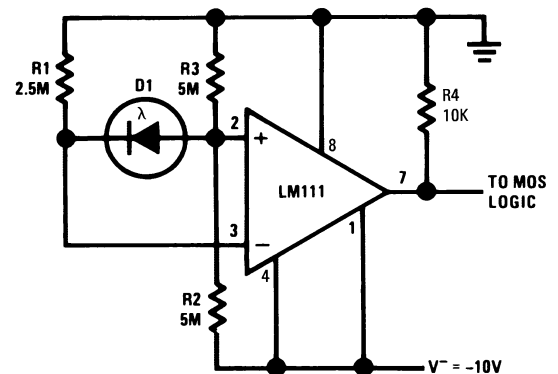

00730303

**FIGURE 3. Level Detector for Photodiode**

Higher threshold currents can be obtained by reducing  $R_1$ ,  $R_2$  and  $R_3$  proportionally. At the switching point, the voltage across the photodiode is nearly zero, so its leakage current does not cause an error. The output switches between ground and  $-10V$ , driving the data inputs of MOS logic directly.

The circuit in *Figure 3* can, of course, be adapted to work with a 5V supply. At any rate, the accuracy of the circuit will depend on the supply-voltage regulation, since the reference is derived from the supply. *Figure 4* shows a method of making performance independent of supply voltage.  $D_1$  is a temperature-compensated reference diode with a 1.23V

## Low Level Applications (Continued)

breakdown voltage. It acts as a shunt regulator and delivers a stable voltage to the comparator. When the diode current is large enough (about  $10\ \mu\text{A}$ ) to make the voltage drop across  $R_3$  equal to the breakdown voltage of  $D_1$ , the output will change state.  $R_2$  has been added to make the threshold error proportional to the offset current of the comparator, rather than the bias current. It can be eliminated if the bias current error is not considered significant.

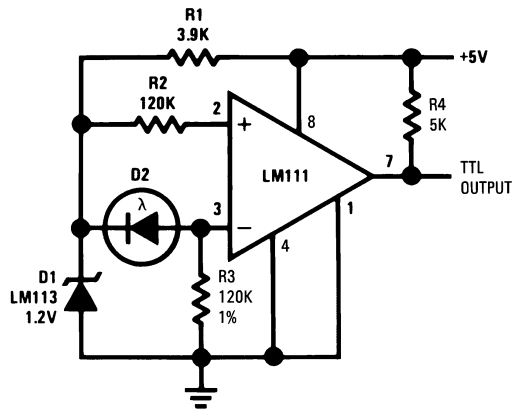

00730304

FIGURE 4. Precision Level Detector for Photodiode

A zero crossing detector that drives the data input of MOS logic is shown in Figure 5. Here, both a positive supply and the  $-10\text{V}$  supply for MOS circuits are used. Both supplies are required for the circuit to work with zero common-mode voltage. An alternate balancing scheme is also shown in the schematic. It differs from the circuit in Figure 2 in that it raises the input-stage current by a factor of three. This increases the rate at which the input voltage follows rapidly-changing signals from  $7\text{V}/\mu\text{s}$  to  $18\text{V}/\mu\text{s}$ . This in-

creased common-mode slew can be obtained without the balancing potentiometer by shorting both balance terminals to the positive-supply terminal. Increased input bias current is the price that must be paid for the faster operation.

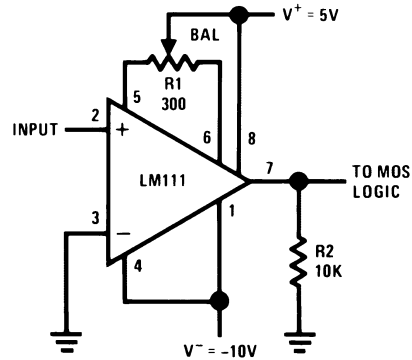

00730305

FIGURE 5. Zero Crossing Detector Driving MOS Logic

## Digital Interface Circuits

Figure 6 shows an interface between high-level logic and DTL or TTL. The input signal, with  $0\text{V}$  and  $30\text{V}$  logic states is attenuated to  $0\text{V}$  and  $5\text{V}$  by  $R_1$  and  $R_2$ .  $R_3$  and  $R_4$  set up a  $2.5\text{V}$  threshold level for the comparator so that it switches when the input goes through  $15\text{V}$ . The response time of the circuit can be controlled with  $C_1$ , if desired, to make it insensitive to fast noise spikes. Because of the low error currents of the LM111, it is possible to get input impedances even higher than the  $300\ \text{k}\Omega$  obtained with the indicated resistor values.

The comparator can be strobed, as shown in Figure 6, by the addition of  $Q_1$  and  $R_5$ . With a logic one on the base of  $Q_1$ , approximately  $2.5\ \text{mA}$  is drawn out of the strobe terminal of the LM111, making the output high independent of the input signal.

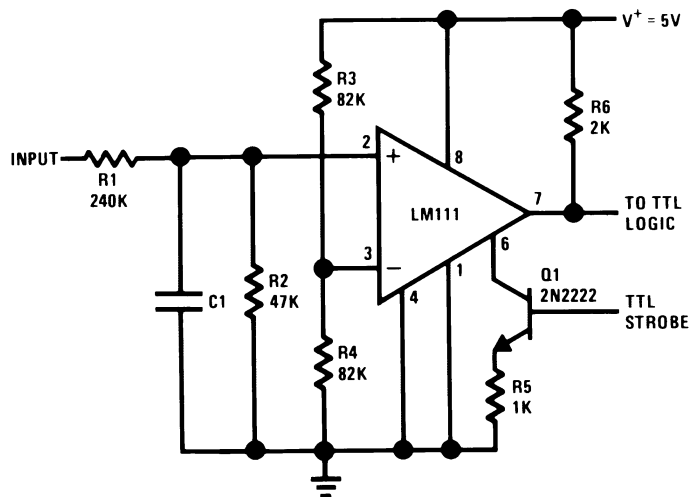

00730306

FIGURE 6. Circuit for Transmitting Data Between High-Level Logic and TTL

## Digital Interface Circuits (Continued)

Sometimes it is necessary to transmit data between digital equipments, yet maintain a high degree of electrical isolation. Normally, this is done with a transformer. However, transformers have problems with low-duty-cycle pulses since they do not preserve the dc level.

The circuit in *Figure 7* is a more satisfactory method of obtaining isolation. At the transmitting end, a TTL gate drives a gallium-arsenide light-emitting diode. The light output is optically coupled to a silicon photodiode, and the comparator detects the photodiode output. The optical coupling makes possible electrical isolation in the thousands of Megohms at potentials in the thousands of volts.

The maximum data rate of this circuit is 1 MHz. At lower rates (~200 kHz)  $R_3$  and  $C_1$  can be eliminated.

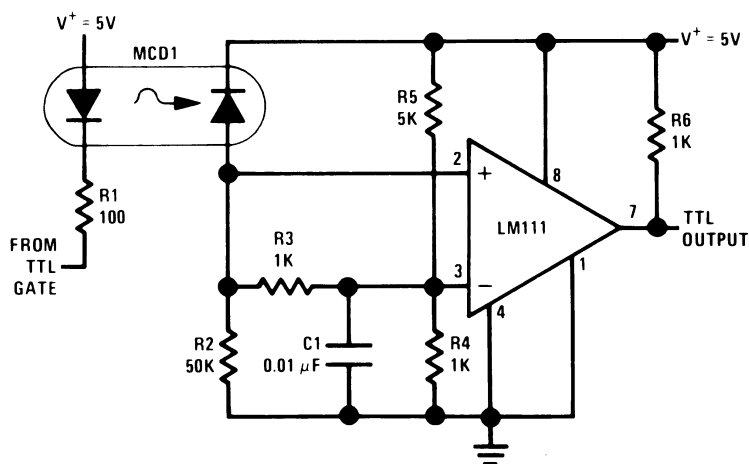

00730307

FIGURE 7. Data Transmission System with Near-Infinite Ground Isolation

Because of the low input current of the comparator, large circuit impedances can be used. Therefore, low frequencies can be obtained with relatively-small capacitor values: it is

no problem to get down to 1 Hz using a 1  $\mu$ F capacitor. The speed of the comparator also permits operation at frequencies above 100 kHz.

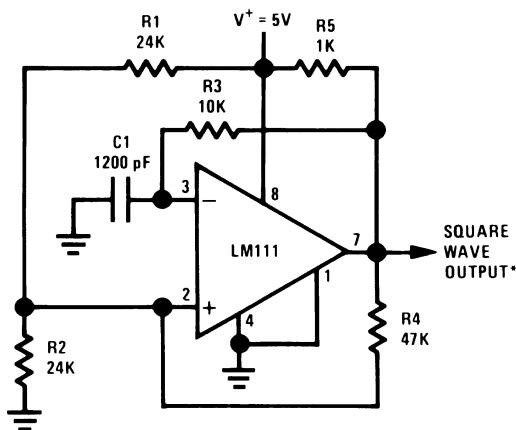

00730308

\* TTL or DTL Fanout of two.

FIGURE 8. Free-Running Multivibrator

## Multivibrators and Oscillators

(Continued)

The frequency of oscillation depends almost entirely on the resistance and capacitor values because of the precision of the comparator. Further, the frequency changes by only 1% for a 10% change in supply voltage. Waveform symmetry is also good, but the symmetry can be varied by changing the ratio of  $R_1$  to  $R_2$ .

A crystal-controlled oscillator that can be used to generate the clock in slower digital systems is shown in *Figure 9*. It is similar to the free running multivibrator, except that the positive feedback is obtained through a quartz crystal. The circuit oscillates when transmission through the crystal is at a maximum, so the crystal operates in its series-resonant mode. The high input impedance of the comparator and the isolating capacitor,  $C_2$ , minimize loading of the crystal and contribute to frequency stability. As shown, the oscillator delivers a 100 kHz square-wave output.

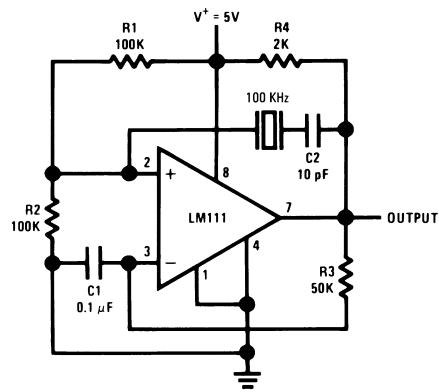

00730309

FIGURE 9. Crystal-controlled Oscillator

## Frequency Doubler

In a digital system, it is a relatively simple matter to divide by any integer. However, multiplying by an integer is quite another story especially if operation over a wide frequency range and waveform symmetry are required.

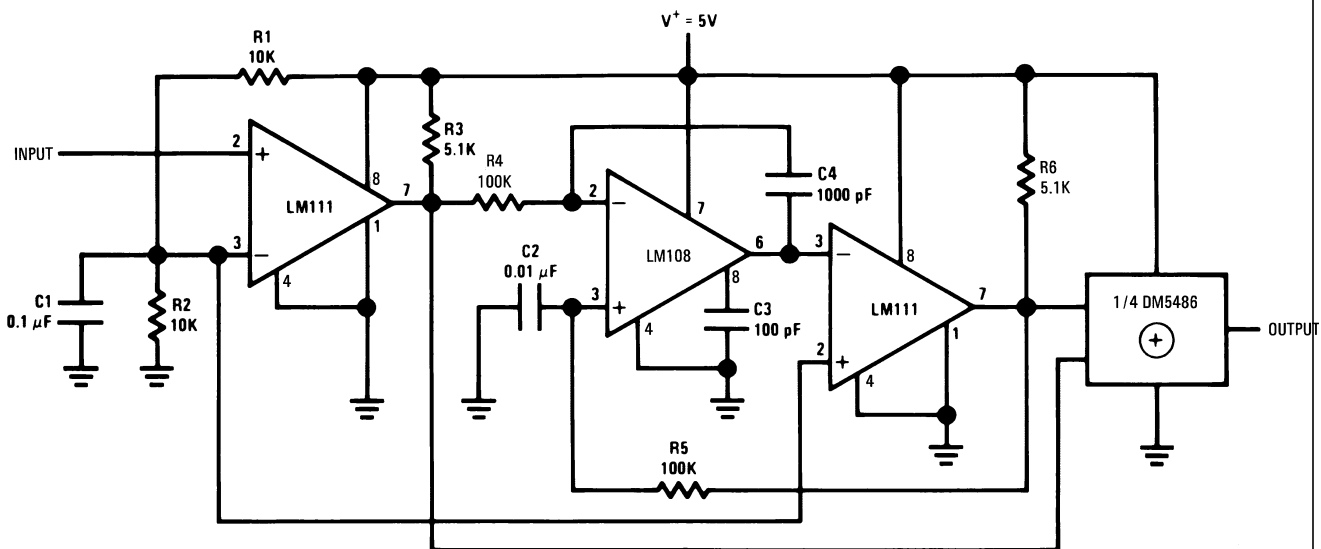

00730310

Frequency Range

Input — 5 kHz to 50 kHz

Output — 10 kHz to 100 kHz

FIGURE 10. Frequency Doubler

A frequency doubler that satisfies the above requirements is shown in *Figure 10*. A comparator is used to shape the input signal and feed it to an integrator. The shaping is required because the input to the integrator must swing between the supply voltage and ground to preserve symmetry in the output waveform. An LM108 op amp, that works from the 5V logic supply, serves as the integrator. This feeds a triangular

waveform to a second comparator that detects when the waveform goes through a voltage equal to its average value. Hence, as shown in *Figure 11*, the output of the second comparator is delayed by half the duration of the input pulse. The two comparator outputs can then be combined through an exclusive-OR gate to produce the double-frequency output.

## Frequency Doubler (Continued)

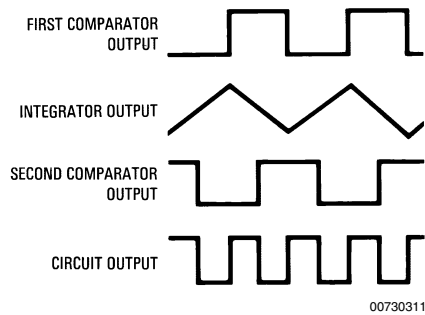

**FIGURE 11. Waveforms for the Frequency Doubler**

With the component values shown, the circuit operates at frequencies from 5 kHz to 50 kHz. Lower frequency operation can be secured by increasing both  $C_2$  and  $C_4$ .

### Application Hints

One of the problems encountered in using earlier IC comparators like the LM710 or LM106 was that they were prone to erratic operation caused by oscillations. This was a direct result of the high speed of the devices, which made it mandatory to provide good input-output isolation and low-inductance bypassing on the supplies. These oscillations could be particularly puzzling when they occurred internally, showing up at the external terminals only as erratic dc characteristics.

In general, the LM111 is less susceptible to spurious oscillations both because of its lower speed (200 ns response time vs 40 ns) and because of its better power supply rejection. Feedback between the output and the input is a lesser problem with a given source resistance. However, the LM111 can operate with source resistance that are orders of magnitude higher than the earlier devices, so stray coupling between the input and output should be minimized. With source resistances between 1 k $\Omega$  and 10 k $\Omega$ , the impedance (both capacitive and resistive) on both inputs should be made equal, as this tends to reject the signal feedback. Even so, it is difficult to completely eliminate oscillations in the linear region with source resistances above 10 k $\Omega$ , because the 1 MHz open loop gain of the comparator is about 80 dB. However, this does not affect the dc characteristics and is not a problem unless the input signal dwells within 200  $\mu$ V of the transition level. But if the oscillation does cause difficulties, it can be eliminated with a small amount of positive feedback around the comparator to give a 1 mV hysteresis.

Stray coupling between the output and the balance terminals can also cause oscillations, so an attempt should be made to keep these leads apart. It is usually advisable to tie the balance pins together to minimize the effect of this feedback. If balancing is used, the same result can be accomplished by connecting a 0.1  $\mu$ F capacitor between these pins.

Normally, individual supply bypasses on every device are unnecessary, although long leads between the comparator and the bypass capacitors are definitely not recommended. If large current spikes are injected into the supplies in switching the output, bypass capacitors should be included at these points.

When driving the inputs from a low impedance source, a limiting resistor should be placed in series with the input lead

to limit the peak current to something less than 100 mA. This is especially important when the inputs go outside a piece of equipment where they could accidentally be connected to high voltage sources. Low impedance sources do not cause a problem unless their output voltage exceeds the negative supply voltage. However, the supplies go to zero when they are turned off, so the isolation is usually needed.

Large capacitors on the input (greater than 0.1  $\mu$ F) should be treated as a low source impedance and isolated with a resistor. A charged capacitor can hold the inputs outside the supply voltage if the supplies are abruptly shut off.

Precautions should be taken to insure that the power supplies for this or any other IC never become reversed—even under transient conditions. With reverse voltages greater than 1V, the IC can conduct excessive current, fusing internal aluminum interconnects. This usually takes more than 0.5A. If there is a possibility of reversal, clamp diodes with an adequate peak current rating should be installed across the supply bus.

No attempt should be made to operate the circuit with the ground terminal at a voltage exceeding either supply voltage. Further, the 50V output-voltage rating applies to the potential between the output and the  $V^-$  terminal. Therefore, if the comparator is operated from a negative supply, the maximum output voltage must be reduced by an amount equal to the voltage on the  $V^-$  terminal.

The output circuitry is protected for shorts across the load. It will not, for example, withstand a short to a voltage more negative than the ground terminal. Additionally, with a sustained short, power dissipation can become excessive if the voltage across the output transistor exceeds about 10V.

The input terminals can exceed the positive supply voltage without causing damage. However, the 30V maximum rating between the inputs and the  $V^-$  terminal must be observed. As mentioned earlier, the inputs should not be driven more negative than the  $V^-$  terminal.

### Conclusions

A versatile voltage comparator that can perform many of the precision functions required in digital systems has been produced. Unlike older comparators, the IC can operate from the same supply voltage as the digital circuits. The comparator is particularly useful in circuits requiring considerable sensitivity and accuracy, such as threshold detectors for low level sensors, data transmission circuits or stable oscillators and multivibrators.

The comparator can also be used in many analog systems. It operates from standard  $\pm 15$ V op amp supplies, and its dc accuracy equals some of the best op amps. It is also an order of magnitude faster than op amps used as comparators.

The new comparator is considerably more flexible than older devices. Not only will it drive RTL, DTL and TTL logic; but also it can interface with MOS logic or deliver  $\pm 15$ V to FET analog switches. The output can switch 50V, 50 mA loads, making it useful as a driver for relays, lamps or light-emitting diodes. Further, a unique output stage enables it to drive loads referred to either supply or to ground and provide ground isolation between the comparator inputs and the load.

The LM111 is a plug-in replacement for comparators like the LM710 and LM106 in applications where speed is not of prime concern. Compared to its predecessors in other respects, it has many improved electrical specifications, more design flexibility and fewer application problems.

**LIFE SUPPORT POLICY**

NATIONAL'S PRODUCTS ARE NOT AUTHORIZED FOR USE AS CRITICAL COMPONENTS IN LIFE SUPPORT DEVICES OR SYSTEMS WITHOUT THE EXPRESS WRITTEN APPROVAL OF THE PRESIDENT AND GENERAL COUNSEL OF NATIONAL SEMICONDUCTOR CORPORATION. As used herein:

1. Life support devices or systems are devices or systems which, (a) are intended for surgical implant into the body, or (b) support or sustain life, and whose failure to perform when properly used in accordance with instructions for use provided in the labeling, can be reasonably expected to result in a significant injury to the user.
2. A critical component is any component of a life support device or system whose failure to perform can be reasonably expected to cause the failure of the life support device or system, or to affect its safety or effectiveness.



**National Semiconductor Corporation**  
Americas  
Email: support@nsc.com

[www.national.com](http://www.national.com)

**National Semiconductor Europe**

Fax: +49 (0) 180-530 85 86  
Email: europe.support@nsc.com  
Deutsch Tel: +49 (0) 69 9508 6208  
English Tel: +44 (0) 870 24 0 2171  
Français Tel: +33 (0) 1 41 91 8790

**National Semiconductor Asia Pacific Customer Response Group**

Tel: 65-2544466  
Fax: 65-2504466  
Email: ap.support@nsc.com

**National Semiconductor Japan Ltd.**

Tel: 81-3-5639-7560  
Fax: 81-3-5639-7507